

WHG Series Intelligent Air Circuit Breaker



Intelligent Air Circuit Breaker

Outline

Scope Of Application

4



Intelligent Air Circuit Breaker

WHG series intelligent air circuit breaker is used for controlling low voltage distribution network, is generally mounted in low voltage distribution board as main switch for protection. Its reproductive products: WHG series isolators installed in distribution circuit to make and break the circuit for isolation. Its performance has reached international advanced level of like products.

- 1.1 Rated current 630~6300A;
- 1.2 Short circuit breaking capacity 85kA (rms);
- 1.3 Rated working voltage AC690V and below;
- 1.4 3P and 4P;
- 1.5 Draw-out type and fixed type;
- 1.6 Inverse feeders (incoming and outgoing cable) mounting available;
- 1.7 Multiple intelligent controllers provide different functions;
- 1.8 The sign of isolation function is "  "
- 1.9 Comply with standards of IEC60947-2,

Model and Meaning

WHG 16 B 3 H

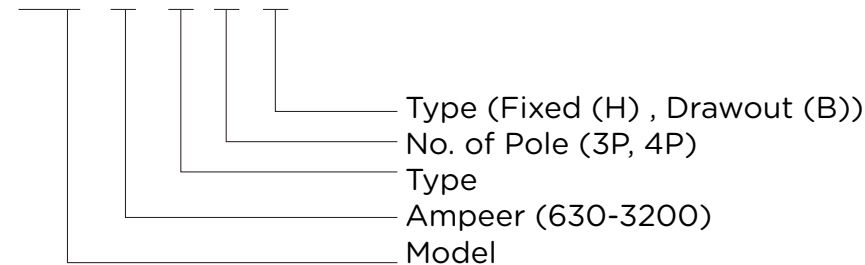

Categories

Installation way: Fixed type and Draw-out type.

Number of pole: 3 pole, 4 pole.

Tripping type: Manual operation, motor operated (and with manual operation).

Trip categories: Intelligent controller, undervoltage instantaneous trip and shunt trip (or time delay type).

Intelligent controller categories: L type (basic type), M type (standard type),

4. Normal working conditions

4.1. Ambient temperature limit within $-5 \sim +40$ degree, average value within 24h not more than 35 degree (except for special requirement);

4.2. Altitude not more than 2000m;

4.3. Relative humidity not more than 50% at highest temperature 40 degree, at lower temperature humidity is allowed for higher value such as 90% at 20 degree, It shall apply for special treatment when temperature variation occurs to clotted dew;

4.4. Polluted grade: Class-3;

4.5. The circuit breaker shall be mounted according to this manual. The mounting vertical angle shall not more than 5 degree;

4.6. If circuit breaker installed in small compartment of the switch board, the protection grade up to IP40, added with door frame, protection grade up to IP54.

Structure introduction

Structure characteristics

1.1. The breaker has fixed type and draw-out type. The fixed type breaker loaded into special drawer then it becomes draw-out type breaker. The breaker consist of contact system, arc-extinguishing system, operating mechanism, current transformer, intelligent controller and auxiliary switches, secondary plug and socket, undervoltage and shunt releases, drawer holder for draw-out type breaker has right and left side plates, base, etc.

1.2. Contact system

One integral contact used, namely different parts of the contact has function of its main contact and arcing contact;
Contact made of new material with the performance of arc high withstand, which it will not lead to high temperature rise even when it break short circuit current.

Contact system adopt the layout mode of multi circuit shunt to reduce the electric stress, improve the electric steadiness.

The distance between moving and static contact is much bigger than 18mm required by standard, completely in compliance with the requirement of safe isolation. The indicator for contact not breaking position is secure and accurate, and only when contact is locked then the breaker can't be closed.

NOTE: "Trip" lock device for breaker is optional but when it used as isolator it is a must.

1.3. Arc-extinguishing chamber.

Each pole has its arc-extinguishing chamber, its function is to separate each electrode, and insulated between each other, isolated from other parts and operator; arc extinguishing chamber enclosed into the insulating base of breaker, enforce the mechanical strength of arc extinguishing chamber wall, and avoid being broken when breaking big short circuit current.

1.4. Operating mechanism, and hand operated, motor operated mechanism

The mechanism is fixed in the front of breaker. Mechanism use five connected rods, free trip structure, energy stored available, once breaker receive the command of closing, breaker can be closed immediately. The stored energy can be released by hand operating button or closing electromagnet. Electric motor driving mechanism become integrated, shaft for energy store coupled with main shaft by active concave and convex part. It is easy to disassembly and assembly.

1.5 Intelligent controller

The frame illustration of intelligent controller (see Pic 1)

1.6. Drawer holder

Drawer holder consist of right and left side plates with rails, base, crossarm. Boosting mechanism provided on the base, position indicator is installed, on top of drawer holder installed with static contact of auxiliary circuit. Bridge type main circuit contacts is ahead separated safely by plate.

1.7. The breaker has three positions during moving. service, test, withdrawn / isolated

"Service" position, main circuit and auxiliary circuit connected, separated plate opened (Pic2)

"Test" position: Main circuit opened, safe separated plate closed, auxiliary connected only. It can perform necessary operation tests.

"Isolated" position: Main and auxiliary circuits are opened, safe separated closed (Pic 4)

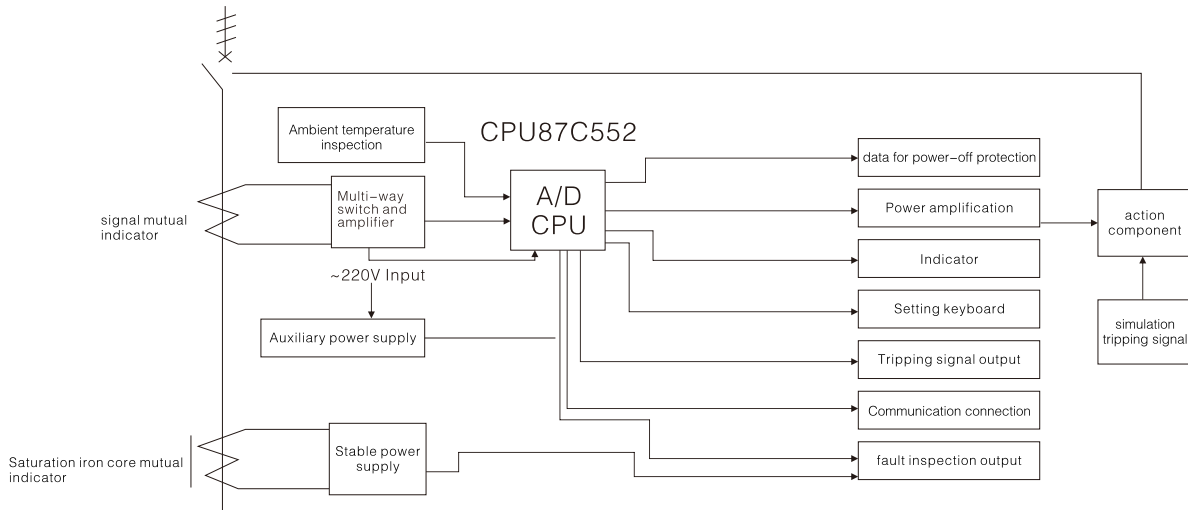

The frame illustration of intelligent controller (Pic 1)

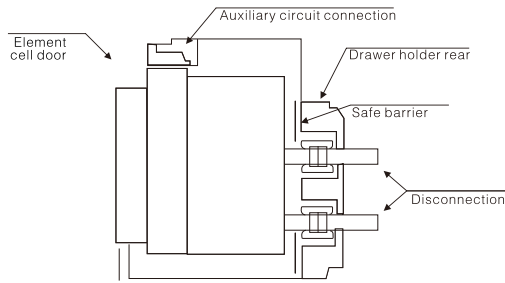

"ON" position (Pic 2)

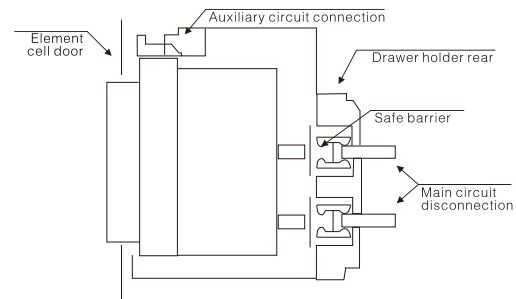

"Test" position (Pic 3)

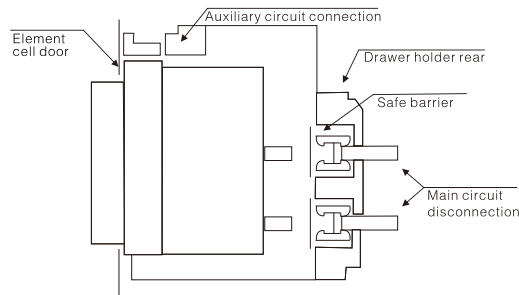

"OFF" position (Pic 4)

Structure anatomy

Front indication of breaker

4

Air Circuit Breakers

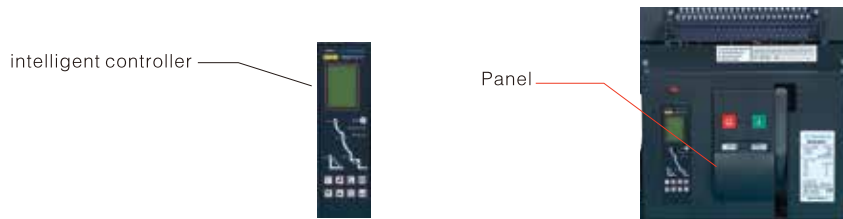
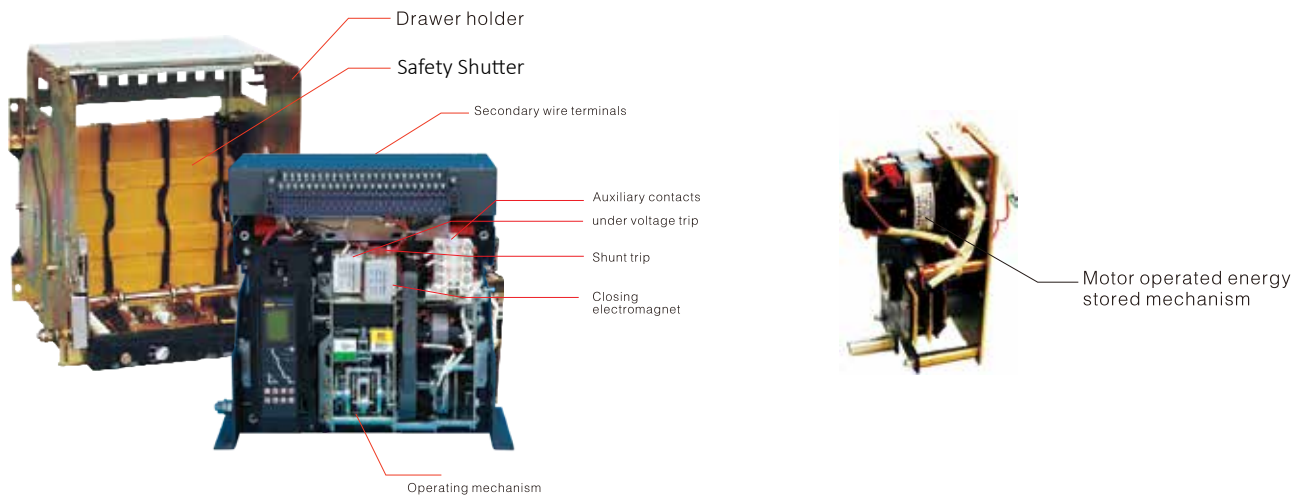

Function instruction for Intelligent Controller

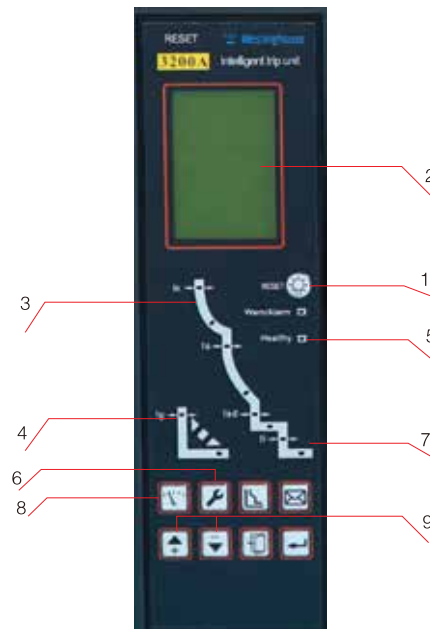

Chart 19

- 1.Reset button.When tripping for fault,if closed again,pls press the reset button otherwise the breaker can't be "OFF"
- 2.Current and time display can show current and time.
- 3.LED luminous indicator shows every status and grade.
- 4.When "select"button is well it show max phase current or max voltage.Press the button,showing every phase of current and voltage circularly.
- 5."Lamp clearing"button for controller setting ,after fault or before breaker closing ,press the button is well to operate.
- 6."Set"button is for inspecting or setting every kind of protection characteristic for current or time ,press this button,showing every status circularly.
- 3.7."Fault inspection"button shows fault status happened last time and fault current and time.
- 3.8."Tripping"and "no tripping"button for test time.
- 3.9."store", "+"and "-"button for setting current or time.

※Note: Controller type explanation:

- 1.Basic type: L2,L3,L4 .
- 2.Standard type: M.
- 3.Other types: 2M, 2H, 3H.

Technique index and characteristics

Technique data

Table 1

Type		WHG-2000										
Inm(A)Rated frame current		2000										
In(A)Rated current		630	800			1000						
Ue(V)Rated working voltage		AC400, 500V 50-60Hz										
Ui(V)Rated insulating voltage		AC1000										
Uimp(V)Rated impulse withstand voltage		8000										
Power frequency withstand voltage		AC3500V 1min										
pole		3、4	3、4			3、4						
In(A)Rated current of N pole		100%In										
Rated ultimate short circuit breaking capacity Icu(kA)rms	AC400, 500V	65	65			65						
Rated operating short circuit breaking capacity Ics(kA)rms	AC400, 500V	65	65			65						
Rated short circuit making capacity Icm(kA)(rms)	AC400, 500V	176	176			176						
Rated short circuit withstand current (Is)Icw(rms)	AC400, 500V	50	50			50						
Full breaking time (no additional delay)		25 ~ 30										
(ms)Closing time		(max)70										
Intelligent controller	Basic type	●	●			●						
	Standard type	●	●			●						
	Other type	●	●			●						
Operation performance (times)	AC400, 500V	6500	6500			6500						
	Maintenance free	15000	15000			15000						
	Maintenance required	30000	30000			30000						
Connection mode		Vertical in horizontal surface			Vertical in horizontal surface			Vertical in horizontal surface				
Mode	Draw-out type	● ●			● ●			● ●				
	Fixed type	● ●			● ●			● ●				
Outline(mm) H x W x L		H	W	L	H	W	L	H	W	L		
Installation	Draw-out type	Horizontal connection	3p	Front installed d								
			Rear installed d	432	375	421	432	375	421	432	375	421
		4p	Front installed d									
			Rear installed d	432	470	421	432	470	421	432	470	421
	Vertical connection	3p	Front installed d									
		Rear installed d										
Fixed type	Horizontal connection	3p	Front installed d									
			Rear installed d	402	362	323	402	362	323	402	362	323
		4p	Front installed d									
			Rear installed d	402	457	323	402	457	323	402	457	323
	Vertical connection	3p	Front installed d									
		Rear installed d										
4p	Front installed d											
	Rear installed d											

Technique data

Table 1

Type		WHG-2000										
Inm(A)Rated frame current		2000										
In(A)Rated current		1250	1600			2000						
Ue(V)Rated working voltage		AC400, 500V 50-60Hz										
Ui(V)Rated insulating voltage		AC1000										
Uimp(V)Rated impulse withstand voltage		8000										
Power frequency withstand voltage		AC3500V 1min										
pole		3、4	3、4			3、4						
In(A)Rated current of N pole		100%In										
Rated ultimate short circuit breaking capacity Icu(kA)rms	AC400, 500V	65	65			65						
Rated operating short circuit breaking capacity Ics (kA)rms	AC400, 500V	65	65			65						
Rated short circuit making capacity Icm(kA)(rms)	AC400, 500V	176	176			176						
Rated short circuit withstand current (Is)Icw(rms)	AC400, 500V	50	50			50						
Full breaking time (no additional delay)		25 ~ 30										
(ms)Closing time		(max)70										
Intelligent controller	Basic type	●	●			●						
	Standard type	●	●			●						
	Other type	●	●			●						
Operation performance (times)	AC400, 500V	6500	6500			6500						
	Maintenance free	15000	15000			15000						
	Maintenance required	30000	30000			30000						
Installation	Connection mode		Vertical in horizontal surface			Vertical in horizontal surface			Vertical in horizontal surface			
	Mode	Draw-out type	● ●			● ●			● ●			
		Fixed type	● ●			● ●			● ●			
	Outline(mm) H × W × L		H	W	L	H	W	L	H	W	L	
	Draw-out type	Horizontal connection	3p	Front installed								
			Rear installed	432	375	421	432	375	421	432	375	421
		4p	Front installed									
			Rear installed	432	470	421	432	470	421	432	470	421
		Vertical connection	3p	Front installed								
			Rear installed									
	Fixed type	Horizontal connection	3p	Front installed								
			Rear installed	402	362	323	402	362	323	402	362	323
		4p	Front installed									
			Rear installed	402	457	323	402	457	323	402	457	323
		Vertical connection	3p	Front installed								
Rear installed												
4p	Front installed											
	Rear installed											

Technique data

Table 2

Type		WHG-3200													
Inm(A)Rated frame current		3200													
In(A)Rated current		2500			2900			3200							
Ue(V)Rated working voltage		AC400, 500V 50-60Hz													
Ui(V)Rated insulating voltage		AC1000													
Uimp(V)Rated impulse withstand voltage		8000													
Power frequency withstand voltage		AC3500V 1min													
pole		3、4			3、4			3、4							
In(A)Rated current of N pole		50%In			100%In										
Rated ultimate short circuit breaking capacity Icu(kA)rms	AC400, 500V	85			85			85			85				
Rated operating short circuit breaking capacity Ics(kA)rms	AC400, 500V	85			85			85			85				
Rated short circuit making capacity Icm(kA)(rms)	AC400, 500V	220			220			220			220				
Rated short circuit withstand current (Is)Icw(rms)	AC400, 500V	65			65			65			65				
Full breaking time (no additional delay)		25 ~ 30													
(ms)Closing time		(max)70													
Intelligent controller	Basic type	●	●	●	●	●	●	●	●	●	●	●	●		
	Standard type	●	●	●	●	●	●	●	●	●	●	●	●		
	Other type	●	●	●	●	●	●	●	●	●	●	●	●		
Operation performance (times)	AC400, 500V	3000			3000			3000			3000				
	Maintenance free	10000			10000			10000			10000				
	Maintenance required	20000			20000			20000			20000				
Connection mode		Horizontal			Horizontal			Horizontal			Horizontal				
Mode	Draw-out type	●	●	●	●	●	●	●	●	●	●	●	●		
	Fixed type	●	●	●	●	●	●	●	●	●	●	●	●		
Outline(mm) H x W x L		H	W	L	H	W	L	H	W	L	H	W	L		
Installation	Draw-out type	Horizontal connection	3p	Front installed											
			Rear installed	432	435	421	432	435	421	432	435	421	432	435	421
		4p	Front installed												
			Rear installed	432	550	421	432	550	421	432	550	421	432	550	421
		Vertical connection	3p	Front installed											
			Rear installed												
Fixed type	Horizontal connection	3p	Front installed												
		Rear installed	402	422	323	402	422	323	402	422	323	402	422	323	
	4p	Front installed													
		Rear installed	402	537	323	402	537	323	402	537	323	402	537	323	
	Vertical connection	3p	Front installed												
		Rear installed													
4p	Front installed														
	Rear installed														

Characteristics

Over load long time delay, reverse time limit operating characteristics

Ir1 Adjustable scope of adjusted current	L type intelligent controller		(0.4 ~ 1.0)In, adjusts by 10% of per grade				
	M H type intelligent controller		(0.4 ~ 1.0)In, adjusts by 2% of per grade				
Permitted current difference is ± 10% permitted operating time is ± 15% (Note: For "I" type no operating with *)	Current	Operating time					
	1.05Ir1	≥ 2h No action					
	1.30Ir1	< 1h Action					
	1.50Ir1(tL)	15s*	30s	60s	120s	240s	480s
	2.00Ir1(TL)	8.4s	16.9s	33.7s	67.5s	135s	270s
Thermal memory function		≤ 30min					

Short time delay operating characteristics

Ir2 Adjustable scope of adjusted current	L type intelligent controller		In, adjusts by 3.4.5.6.7.8.10 time each grade					
	M H type intelligent controller		In, adjusts by 4% of each grade					
Permitted current difference is ± 10% permitted operating time is ± 15% (Note: For "ts" type no operating with *)	Current	Operating time						
	I ≤ 8Ir1	+ OFF reverse time limit			I ² ts = (8Ir1) ² tL			
		Definit-time limit	ts Setting time	0.1*	0.2	0.3*	0.4	
	(s) Return time		0.06	0.14	0.23	0.35		
Thermal memory function		≤ 15min						

Short time delay operating characteristics

Adjustable range adjusted current permitted difference of ± 15%	L type intelligent controller	Inm=2000A	(10 ~ 20)In				
		Inm=3200A	(7 ~ 14)In				
	M H type intelligent controller	Inm=2000A	1.0In ~ 50KA, Adjusts by 8% of per grade				
		Inm=3200A	1.0In ~ 75KA, Adjusts by 8% of per grade				

Earthing-fault operating characteristics

Ir4 Adjustable scope of adjusted current	L M H type intelligent controller		(0.2 ~ 0.9)In (max 1200A, min 160A)				
Permitted current difference is ± 10% permitted operating time is ± 15% (Note: For "tg" type no operating time with *)	Operating characteristics		Action within 0.9Ir4 - 1.1Ir4 ≤ 0.9Ir4 no action > 1.1Ir4 action				
	Regular time limit	tg(S) Adjusted current	0.1*	0.2	0.3*	0.4	OFF
		Return time(S)	0.06	0.14	0.23	0.35	Only alarm but no break

load monitoring operating characteristics

model 1	Adjustable range of adjusted current permitted difference of $\pm 10\%$	$(0.1-1.0)I_n$, adjusts by 20A of each grade
	Time delay characteristic t_1/t_2	Reverse time limit characteristics $t_{c1}=1/2t_L$ 、 $t_{c2}=1/4t_L$
model 2	Adjustable range of adjusted current permitted difference of $\pm 10\%$	$(0.2-0.1)I_n$, adjusts by 20A of each grade
	Time delay characteristic t_1/t_2	Reverse time limit characteristics $t_{c1}=1/2t_L$
		Reverse time limit characteristics $T_{c2}=60s$

Note: these parameter for M H type intelligent controller, L type intelligent controller of absence.

conventional parameter enactment when exworks

unless users indicate specially, the factory setting intelligent controller parameters as following:

Type	Overload long time delay adjusting		Short-circuit short time delay adjusting		Short-circuit instantaneous adjusting	Earthing-fault protect and adjust		Loading inspecting adjust	
	I_{r1}	$TL(1.5I_{r1})$	I_{r2}	t_s	I_{r3}	I_{r4}	t_G	ILC1	ILC2
WHG-2000	I_n	240s	$8I_{r1}$	0.4s	$12I_n$	$0.5I_n$	0.4s	I_n	I_n
WHG-3200	I_n	240s	$8I_{r1}$	0.4s	$12I_n$	$0.5I_n$	0.4s	I_n	I_n

Tripping characteristics curve

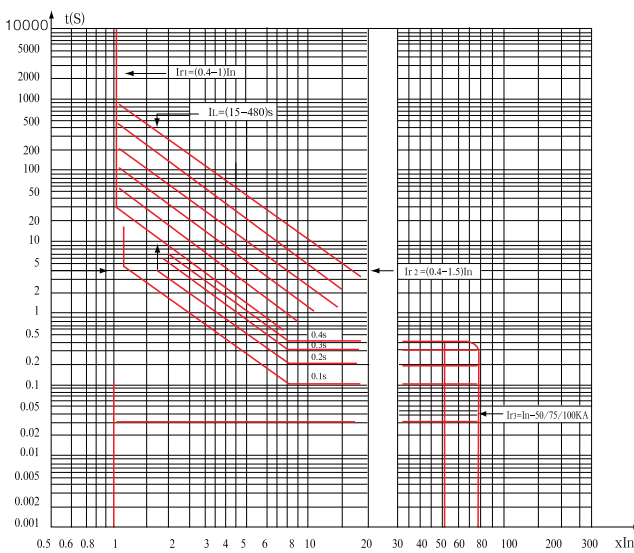

Table 1

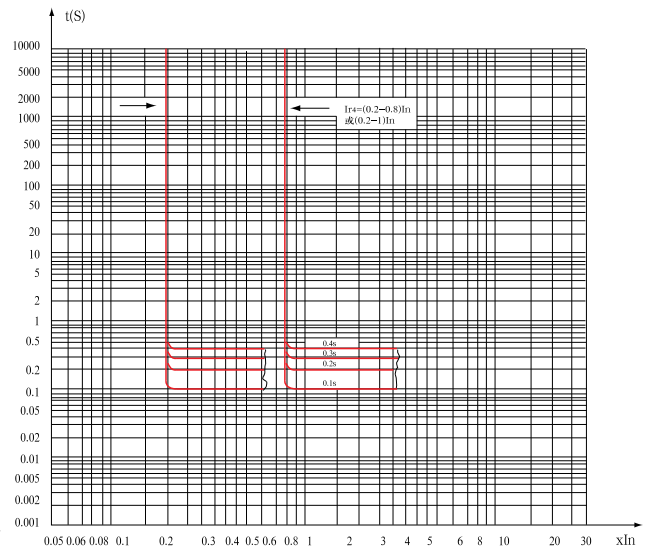

Table 2

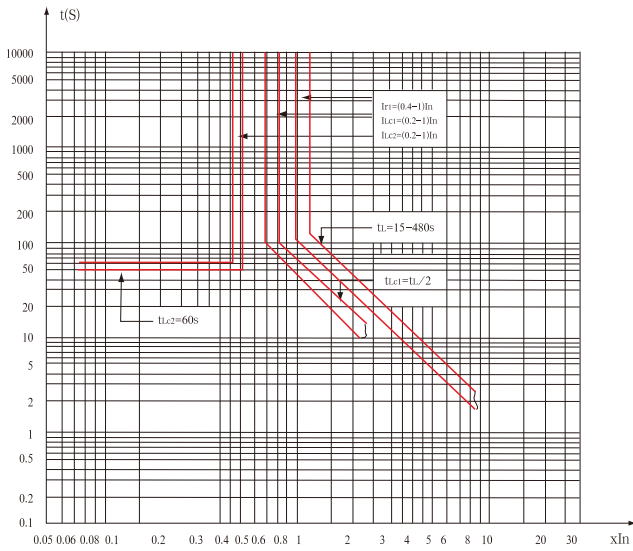

Table 3

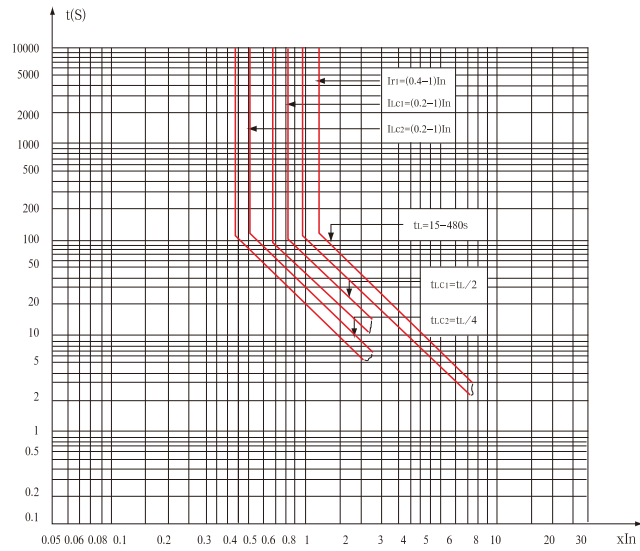

Table 4

Product Accessories

Operation mechanism

Operation mechanism lies in the frontage of breaker, adopted free tripping device of five-barlinkage, and with design of energy storage form. During using process, when operation mechanism is in energy storage position, only if the breaker received the command of closing, it will close immediately. The release of pre-stored energy can be completed by manual energy release button and energy release electromagnet. Energy storage of breaker is operating by electrical-operation device (with manual operation).

The characteristic of electrical-operation device is in the following table:



Us Rated controlling voltage	AC (50-60Hz)		DC	
	220V	380V	110V	220V
Operating voltage	(85% ~ 110%)Us		(85% ~ 110%)Us	
Power consumption	Inm=2000A	85VA	85W	
	Inm=3200A	110VA	110W	
energy stored time	≤5s		≤5s	



Energy release electromagnet

After motor finished energy storage , energy release electromagnet makes the energy storage spring of electrical-operation device release instantaneously,then the breaker closed quickly

The characteristic of Energy release electromagnet in the following

Us Rated controlling voltage	AC (50-60Hz)		DC	
	220V	380V	110V	220V
Operating voltage	(85% ~ 110%)Us		(85% ~ 110%)Us	
Power consumption	40VA		40W	
Closing time	≤70ms		≤70ms	



Undervoltage trip

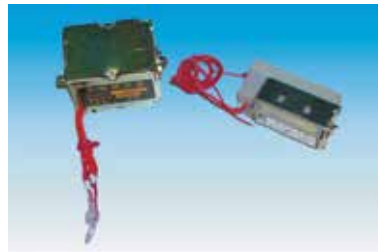

Shunt trip



Auxiliary contact

Undervoltage trip

Undervoltage trip is combined of undervoltage trip coil and controlling unit .There are two types of undervoltage trip,they are undervoltage instantaneous trip and undervoltage time-delay trip.

The characteristic of Undervoltage trip in the following table

UeRated controlling voltage		AC 220 (50-60Hz)	AC 380 (50-60Hz)
Operating voltage		(35% ~ 70%)Ue	
Guarantee closing voltage		(85% ~ 110%)Ue	
Guarantee non-closing voltage		≤35%Ue	
Power consumption		24VA	24VA
Opreating time of trip	Undervoltage instantaneous trip	Instantaneous	
	Undervoltage time-dely trip	Within half of time-delay time,when voltage comes back to 85% Ue,breaker will not be "OFF"	

Shunt trip

Shunt trip is a kind of device applied to make the breaker “OFF” ?
The characteristic of shunt trip is in the following table:

Us Rated controlling voltage	AC (50-60Hz)		DC	
	AC220V	AC380V	110V	220V
Operating voltage	(70% ~ 110%)Us		(70% ~ 110%)Us	
Power consumption	40VA		40W	
Breaking time	≤30ms		≤30ms	

Auxiliary contact

The characteristic of auxiliary contact is in the following table:

Usage categories	AC-15		DC-13	
Rated working voltage	AC220V	AC380V	DC110V	DC220V
Rated thermal current	6A		6A	
Rated controlling capacity	300VA		60W	
Contact form	Standard type:4NO 4NC special type 5NO 5NC			

Key Interlock



“OFF” locking device

OFF Locking device can make the off button in down position, at this time breaker can't do on and offoperation.. One breaker equips with one lock and one key; Two breakers equip with two same locks and keys;three breakers with three same locks and keys.

Door frame



Door frame installed in the door of small cabinet for sealing protection, up to protection grade IP40, which is suitable for draw-out type and fixed type breaker.



Phase barrier

Phase barrier can strengthen insulating intensity of phase barrier

Mechanism interlocking

Suitable for power supply system of multiple power source Mechanism interlocking includes two types: wire rope interlocking and connecting rod interlocking

1. Two horizontal breakers for wire rope interlocking, two same side faces distance is 2m
2. Two or three vertical breakers for connecting rod interlocking, Bottom distance of two breakers in 0.9m.

Connecting rod interlocking

Two or three piled breakers for connecting rod interlocking.

Three piled breakers for connecting rod interlocking. If two breakers, just delete the breaker on upper most position. (see drawing 1)

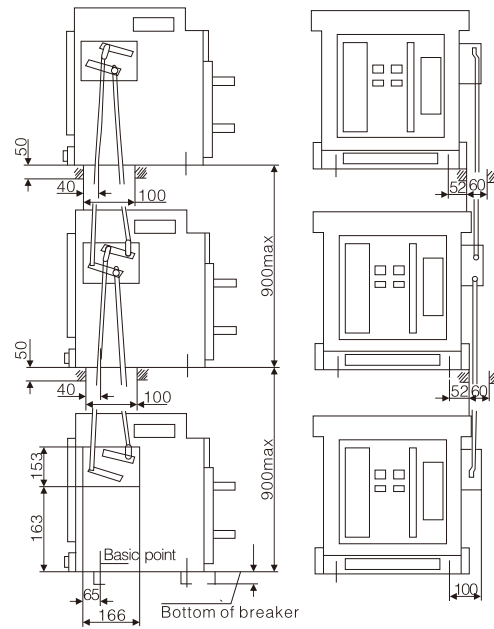
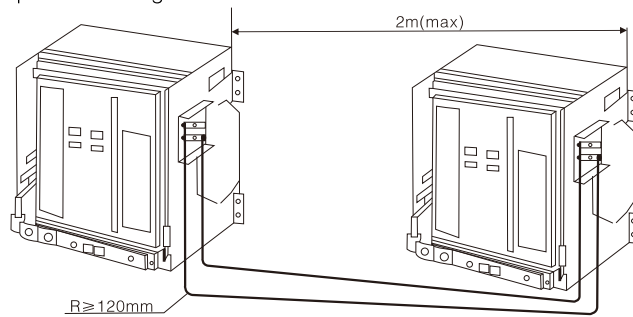

chart 1

wire rope interlocking

(Cable) Interlock



Two horizontal breakers for wire rope interlocking. (see drawing 2)

Other accessories

When choose H Type intelligent controller, power source module, relay module, agreed editor and other accessories are for choosing. when power source is Direct Current, AC module should be added. When choosing selection earth-leakage protection, outside-connected mutual inductor should be added.

External and assembly dimensions

WHG 2000A

fixed type breakers External and assembly dimensions see pic 15-1、15-2

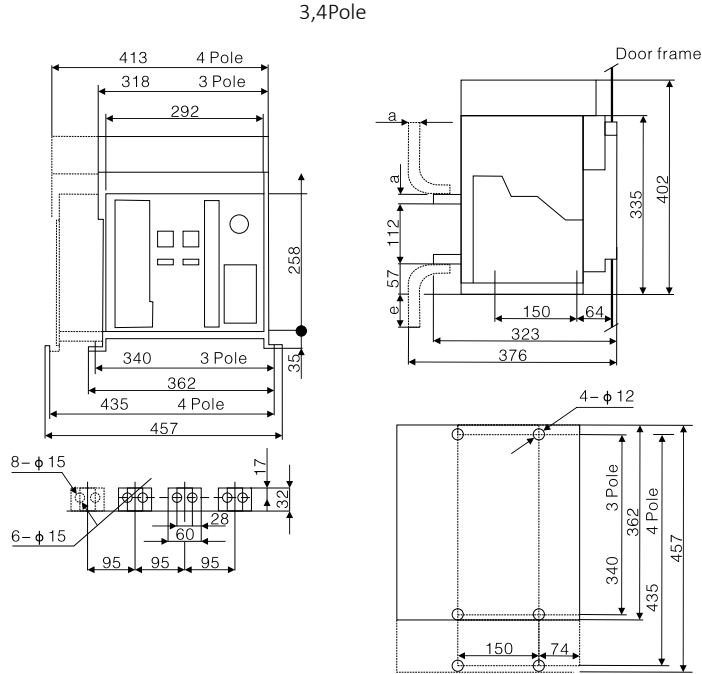

Fixed type breakers see drawing 15

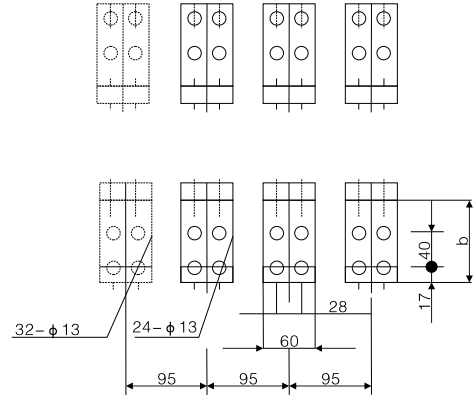

rear-front connected

In/A	a/mm	b/mm	e/mm
630-800	10	95	38
1000-1600	15	105	48
2000	20	115	58

(Inm=2000A)

fixed type breakers External and assembly dimensions

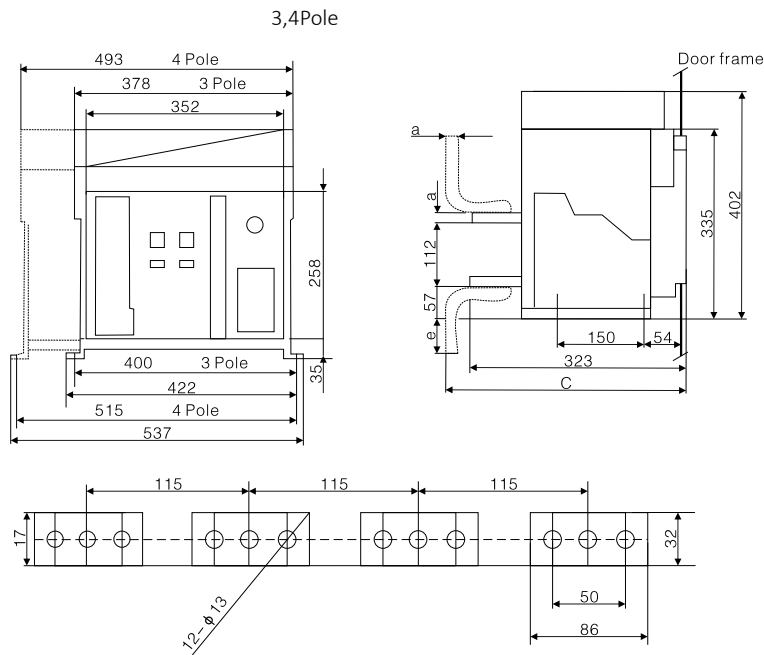

WHG 3200A

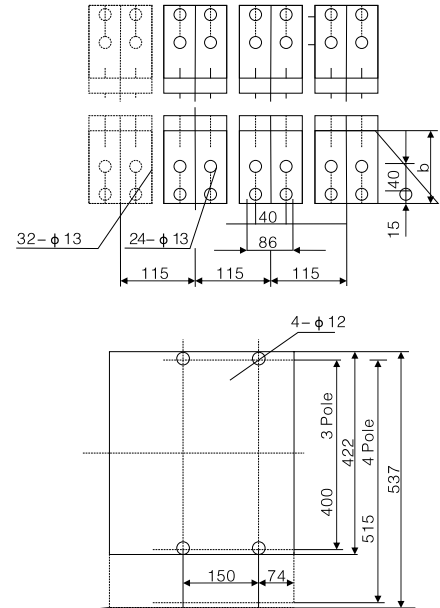

(Inm=3200A)

fixed type breakers External and assembly dimensions

In/A	a/mm	b/mm	c/mm	e/mm
2000.2500	20	115	408	58
2900.3200	30	135	428	78

Draw-out type breaker's external and assembly dimensions see drawing

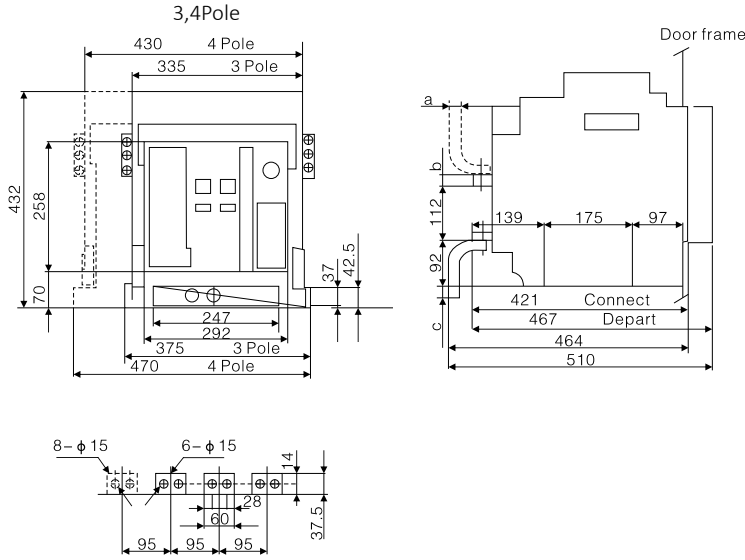

WHG 2000A

Draw-out type breaker

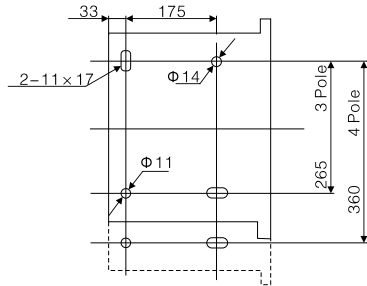
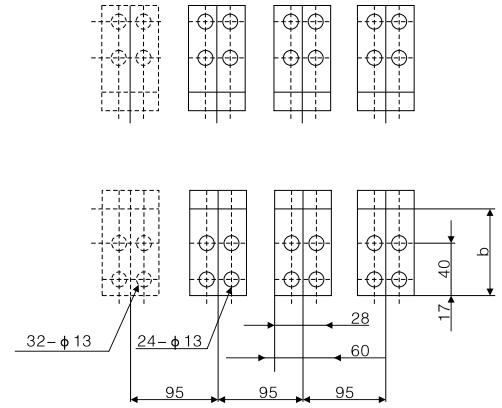

In/A	a/mm	b/mm	e/mm
630-800	10	95	3
1000-1600	15	105	13
2000	20	115	23

(Inm=2000A)

Draw-out type breaker's external and assembly dimensions see drawing (Inm=2000A)

3,4 Pole

WHG 3200A

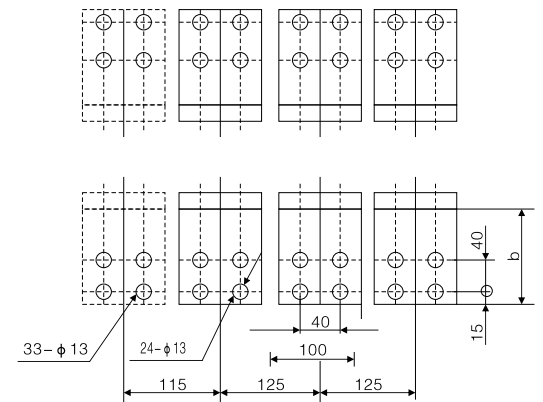
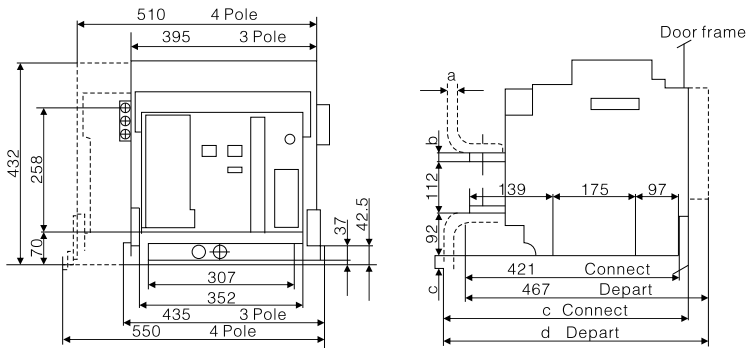

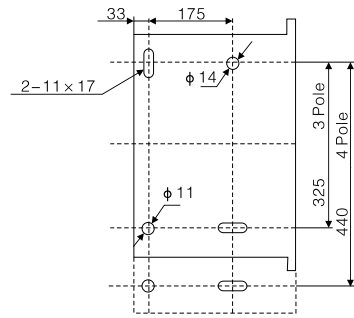
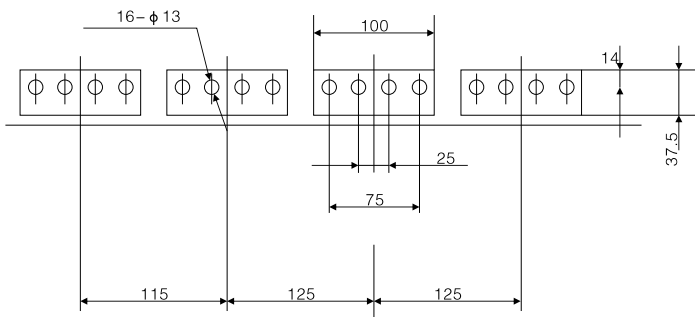

In/A	a/mm	b/mm	c/mm	d/mm	e/mm
2500	20	115	506	552	23
3200	30	135	526	572	43

Connection diagram of secondary circuit coils

4

Air Circuit Breakers

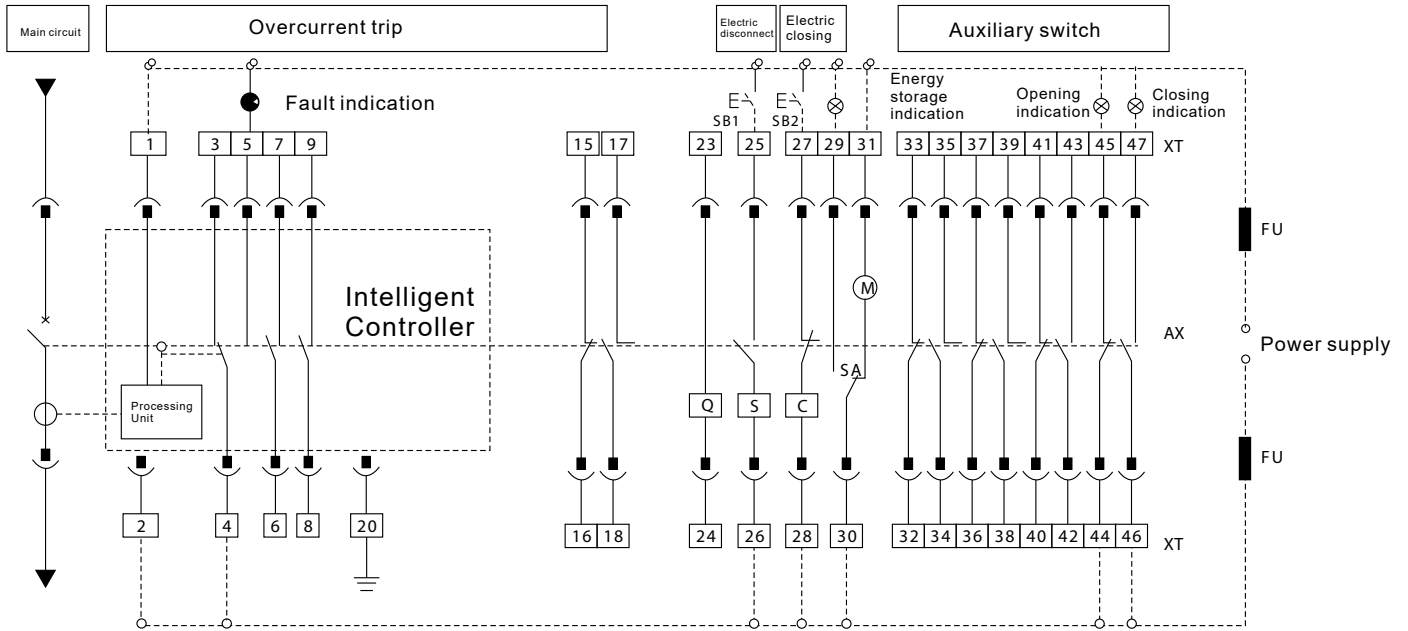

Note:

1. The dotted line is connected by user.
2. Terminal function # 1 . # 2 : Auxiliary Power Input , DC when # 1 foot is positive # 3 , # 4 # 5 : Fault trip contact # 6 , # 7 # , 8 # , 9 # : State auxiliary contact # 20: Ground Wire

3. Code name

- AX: CIRCUIT BREAKER AUXILIARY SWITCH
- SB1: SHUNT BUTTON
- SB2: Close Button
- Q : under - voltage release (terminal 23, 24 should be connected in the main circuit)
- S : shunt release
- C : Close electromagnet
- M : Storage Motor
- SA: Motor travel switch
- XT: Circuit Breaker Secondary Loop Terminal
- Fu: Fuse
- 30, 31: direct power (automatic pre- storage energy) Can also be series open button, after the power supply
- (manual pre- storage energy) power : If the processing unit , Q, S, C and other rated voltage should be connected separately can not power supply

The auxiliary switch consists of five normally open contacts and five normally closed contacts

- U: Undervoltage Release**
- S: Shunt Release ST**
- C: Closing coil CC**
- M: Motor charge**

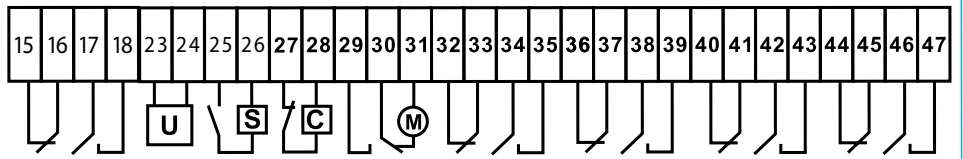

Install usage with maintenance

Mounting

1. When insulating resistance reached to users' request the breaker can be used.
2. Before installation, please measure the insulating resistance of breakers by 1000VDC megger. The resistance under $25 \pm 5^\circ\text{C}$ degree and humidity 50~70% shall not less than $20\text{M}\Omega$, or the breaker shall be dried. When insulating resistance reached to users' request, then breaker can be used.
3. During installation, the base is in horizon, and fixed by M10 screws.
4. During installation the breaker shall be securely earthed, where there shall have legible mark.
5. No matter it comes from upper or downward of breaker, it does not effect the performances of breaker.
6. After installation and wiring according to diagram, before main circuit energized, (the indicator on the drawer holder of draw-out breaker shall be in "test" position), it shall perform the following operation tests.
 - a. Check if undervoltage trip, shunt releases, closing electromagnet, and motor operated mechanism are in compliance or not (before closing breaker, undervoltage trip release shall be energized)
 - b. Sway the handle up and down 7 times, then it display "Energy stored" and make a sound of "kada", it mean energy storing finished. Push button or make closing electromagnet energized, then breaker can be closed securely (in the case that the controller being securely reset)
 - c. Make Motor operated till it display "Energy stored" and make a sound of "kada", it mean energy storing finished. Push button or make "closing" electromagnet energized, then breaker can be closed securely.
 - d. After breaker closed, no matter which button of absent voltage, shunt release or in the panel is pushed, this test shall all make breaker trip from intelligent controller.

Fault analysis and solutions

Table 3

No.	Fault phenomenon	Reason	solution
1	breaker can not be closed	Absent voltage release has no power supply, unenergized Intelligent controller make action, but the red button in control panel does not reset. Operating mechanism has no energy stored. Draw-out breaker is not in "ON" or "Test" position, key for "OFF" position is locked.	Check circuit, switch on the power supply for absent voltage release Push "Reset" button hand or motor operating make mechanism energy stored Sway the handle and make break locate in "ON" or "TEST" position. Use special key to open the lock.

Fault analysis and solutions

No.	Fault phenomenon	Reason	solution
2	Breaker can not make energy stored by motor	Power supply for the motor operated mechanism is not closed or the power is not enough.	Check the circuit, switch on power supply The operating voltage shall be more than 85% Ue
3	Closing electromagnet can't make breaker closed	No power supply, power is not enough	Check the circuit, switch on power supply The operating voltage shall be more than 85% Ue
4	Shunt release can't make breaker trip	No power supply, power is not enough	Check the circuit, switch on power supply The operating voltage shall be more than 85% Ue
5	The fault current is more than the setting values of long time delay, short time delay, and instantaneous, but the breaker only trip instantaneously without short time delay or long time delay.	Values of long time delay, short time delay, instantaneous settings are in adjacent range, not reasonably.	Reset the value in compliance with specified range as $I_{r1} < I_{r2} < I_{r3}$
6	Breaker trip frequently	The on-site loading lead to over loading trip, it is caused that thermal overloading record is not be cleaned off on time, so it reclosed.	Cut off the power supply for controller one time, or after 30min reclose breaker
7	The handle for draw-out type breaker can't be inserted into the breaker	Railway or breaker is not pushed inside completely in place.	Push railway or breaker inside completely
8	When the breaker is in "OFF" position, the breaker is not allowed to be drawn out	Handle not pulled out, breaker does not reach completely "OFF" position	Pull out handle Sway the handle and make breaker under "OFF" position

Order Reference Table

ACB WHG SERIES		
Reference No.	Catalogue No.	DESCRIPTION
ACB 3P FIXED TYPE WITH CT AND AUX CONTRACT, OCR CONTROL UNIT		
W605950	WHG06A3H	ACB FIXED TYPE 3P 630A 65kA WITH CT , AUXILIARY CONTACT , OCR CONTROL UNIT (BUSBAR SIZE: 60x15MM)
W605918	WHG08A3H	ACB FIXED TYPE 3P 800A 65kA WITH CT , AUXILIARY CONTACT , OCR CONTROL UNIT (BUSBAR SIZE: 60x15MM)
W605920	WHG10A3H	ACB FIXED TYPE 3P 1000A 65kA WITH CT , AUXILIARY CONTACT , OCR CONTROL UNIT (BUSBAR SIZE: 60x15MM)
W605922	WHG12A3H	ACB FIXED TYPE 3P 1250A 65kA WITH CT , AUXILIARY CONTACT , OCR CONTROL UNIT (BUSBAR SIZE: 60x15MM)
W605924	WHG16A3H	ACB FIXED TYPE 3P 1600A 65kA WITH CT , AUXILIARY CONTACT , OCR CONTROL UNIT (BUSBAR SIZE: 60x15MM)
W605926	WHG20A3H	ACB FIXED TYPE 3P 2000A 65kA WITH CT , AUXILIARY CONTACT , OCR CONTROL UNIT (BUSBAR SIZE: 60x20MM)
W605928	WHG25B3H	ACB FIXED TYPE 3P 2500A 85kA WITH CT , AUXILIARY CONTACT , OCR CONTROL UNIT (BUSBAR SIZE: 86x20MM)
W605930	WHG32B3H	ACB FIXED TYPE 3P 3200A 85kA WITH CT , AUXILIARY CONTACT , OCR CONTROL UNIT (BUSBAR SIZE: 86x30MM)
ACB 4P FIXED TYPE WITH CT AND AUX CONTRACT, OCR CONTROL UNIT		
W605950	WHG06A4H	ACB FIXED TYPE 4P 630A 65kA WITH CT , AUXILIARY CONTACT , OCR CONTROL UNIT (BUSBAR SIZE: 60x15MM)
W605919	WHG08A4H	ACB FIXED TYPE 4P 800A 65kA WITH CT AND AUXILIARY CONTRACT, OCR CONTROL UNIT (BUSBAR SIZE: 60x15MM)
W605921	WHG10A4H	ACB FIXED TYPE 4P 1000A 65kA WITH CT AND AUXILIARY CONTACT, OCR CONTROL UNIT (BUSBAR SIZE: 60x15MM)
W605923	WHG12A4H	ACB FIXED TYPE 4P 1250A 65kA WITH CT AND AUXILIARY CONTACT, OCR CONTROL UNIT (BUSBAR SIZE: 60x15MM)
W605925	WHG16A4H	ACB FIXED TYPE 4P 1600A 65kA WITH CT AND AUXILIARY CONTACT, OCR CONTROL UNIT (BUSBAR SIZE: 60x15MM)
W605927	WHG20A4H	ACB FIXED TYPE 4P 2000A 65kA WITH CT AND AUXILIARY CONTACT, OCR CONTROL UNIT (BUSBAR SIZE: 60x20MM)
W605929	WHG25B4H	ACB FIXED TYPE 4P 2500A 85kA WITH CT AND AUXILIARY CONTACT, OCR CONTROL UNIT (BUSBAR SIZE: 86x20MM)
W605931	WHG32B4H	ACB FIXED TYPE 4P 3200A 85kA WITH CT AND AUXILIARY CONTACT, OCR CONTROL UNIT (BUSBAR SIZE: 86x30MM)
W606545	WAM5	ACB MOTOR (A) AC230V/DC220V WITH BOLT
W606546	WMB5	ACB MOTOR (B) AC230V/DC220V WITH MOUNTING SCREW
W606547	WU5	ACB UNDERVOLTAGE TRIP COIL W/ UNDERVOLTAGE RELEASE AC230V/DC220V
W606548	WC5	CLOSING COIL CC AC/DC 220V
W606549	WMIC3M	MECHANICAL INTERLOCK CABLE 3M FOR ACB
W606550	WS5	SHUNT TRIP AC230/DC220V



Westinghouse

Westinghouse

Pennsylvania , USA

Westinghouse LV MV Product sp. z o.o.

Warsaw, Poland

Westinghouse Lv Mv Product Sdn. Bhd.

Penang, Malaysia

Westinghouse LV MV Product

Dubai, UAE

Westinghouse LV MV Product

Istanbul, Turkey

WWW.westinghouselvmv.com

Email: info@westinghouselvmv.com